

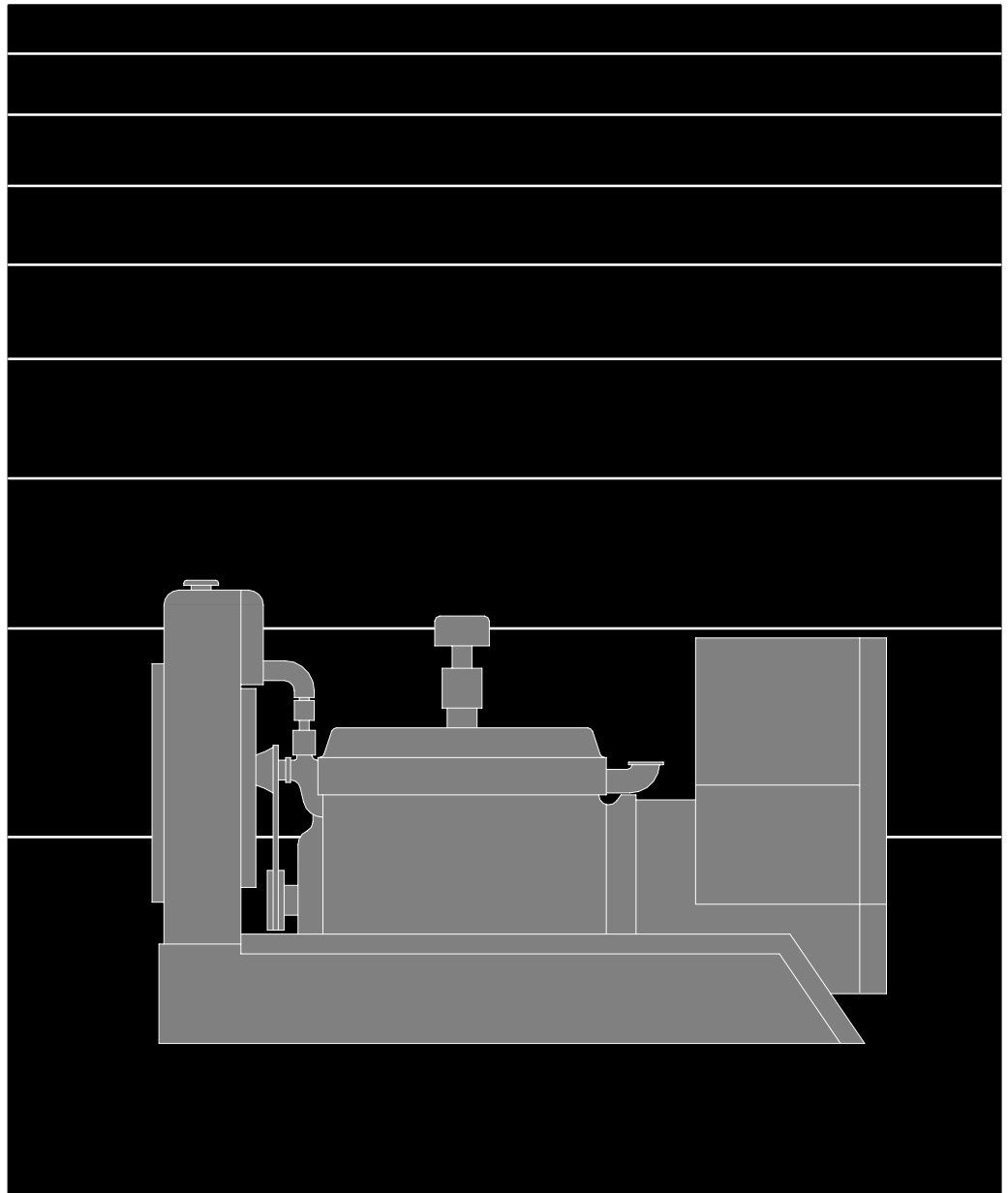

# Operator's Manual

## EK-EM GENERATOR SET



Printed U.S.A.

928-0120 12-95

# Table of Contents

---

SECTION	TITLE	PAGE
	<b>SAFETY PRECAUTIONS</b> .....	ii, iii
<b>1</b>	<b>INTRODUCTION</b> .....	1-1
	About This Manual .....	1-1
	How To Obtain Service .....	1-1
<b>2</b>	<b>SPECIFICATIONS</b> .....	2-1
<b>3</b>	<b>OPERATION</b> .....	3-1
	General .....	3-1
	Prestart Checks .....	3-1
	Control Panel .....	3-1
	Generator AC Voltage Regulator .....	3-5
	Engine Control Module .....	3-5
	Starting .....	3-6
	Stopping .....	3-7
	Break-In .....	3-7
	No-Load Operation .....	3-7
	Exercise Period .....	3-7
	High/Low Operating Temperatures .....	3-7
	Power Rating Factors .....	3-7
<b>4</b>	<b>TROUBLESHOOTING</b> .....	4-1
	Safety Considerations .....	4-1
<b>5</b>	<b>MAINTENANCE</b> .....	5-1
	Maintenance .....	5-1
	Generator Set Inspection .....	5-2
	Lubrication System .....	5-3
	Cooling System .....	5-5
	Air Filter .....	5-6
	Fuel Filter .....	5-7
	Drive Belts .....	5-7
	Ignition System .....	5-8
	Battery .....	5-9
	Out-Of-Service Protection .....	5-9
<b>6</b>	<b>ADJUSTMENTS</b> .....	6-1
	Output Voltage Adjustment .....	6-1
	Fuel System Adjustments .....	6-1

**▲ WARNING: ▲**

The engine exhaust from this product contains chemicals known to the State of California to cause cancer, birth defects or other reproductive harm.

# Safety Precautions

---

**Before operating the generator set**, read the Operator's Manual and become familiar with it and the equipment. **Safe and efficient operation can be achieved only if the equipment is properly operated and maintained.** Many accidents are caused by failure to follow fundamental rules and precautions.

The following symbols, found throughout this manual, alert you to potentially dangerous conditions to the operator, service personnel, or the equipment.

**⚠ DANGER** *This symbol warns of immediate hazards which will result in severe personal injury or death.*

**⚠ WARNING** *This symbol refers to a hazard or unsafe practice which can result in severe personal injury or death.*

**⚠ CAUTION** *This symbol refers to a hazard or unsafe practice which can result in personal injury or product or property damage.*

## FUEL AND FUMES ARE FLAMMABLE

Fire, explosion, and personal injury or death can result from improper practices.

- DO NOT fill fuel tanks while engine is running, unless tanks are outside the engine compartment. Fuel contact with hot engine or exhaust is a potential fire hazard.
- DO NOT permit any flame, cigarette, pilot light, spark, arcing equipment, or other ignition source near the generator set or fuel tank.
- Fuel lines must be adequately secured and free of leaks. Fuel connection at the engine should be made with an approved flexible line. Do not use copper piping on flexible lines as copper will become brittle if continuously vibrated or repeatedly bent.
- Be sure all fuel supplies have a positive shutoff valve.

- Be sure battery area has been well-ventilated prior to servicing near it. Lead-acid batteries emit a highly explosive hydrogen gas that can be ignited by arcing, sparking, smoking, etc..

## EXHAUST GASES ARE DEADLY

- Provide an adequate exhaust system to properly expel discharged gases away from enclosed or sheltered areas and areas where individuals are likely to congregate. Visually and audibly inspect the exhaust daily for leaks per the maintenance schedule. Ensure that exhaust manifolds are secured and not warped. Do not use exhaust gases to heat a compartment.
- Be sure the unit is well ventilated.
- Engine exhaust and some of its constituents are known to the state of California to cause cancer, birth defects, and other reproductive harm.

## MOVING PARTS CAN CAUSE SEVERE PERSONAL INJURY OR DEATH

- Keep your hands, clothing, and jewelry away from moving parts.
- Before starting work on the generator set, disconnect battery charger from its AC source, then disconnect starting batteries, negative (-) cable first. This will prevent accidental starting.
- Make sure that fasteners on the generator set are secure. Tighten supports and clamps, keep guards in position over fans, drive belts, etc.
- Do not wear loose clothing or jewelry in the vicinity of moving parts, or while working on electrical equipment. Loose clothing and jewelry can become caught in moving parts. Jewelry can short out electrical contacts and cause shock or burning.
- If adjustment must be made while the unit is running, use extreme caution around hot manifolds, moving parts, etc.

## **ELECTRICAL SHOCK CAN CAUSE SEVERE PERSONAL INJURY OR DEATH**

- Remove electric power before removing protective shields or touching electrical equipment. Use rubber insulative mats placed on dry wood platforms over floors that are metal or concrete when around electrical equipment. Do not wear damp clothing (particularly wet shoes) or allow skin surface to be damp when handling electrical equipment.
- Use extreme caution when working on electrical components. High voltages can cause injury or death. DO NOT tamper with interlocks.
- Follow all applicable state and local electrical codes. Have all electrical installations performed by a qualified licensed electrician. Tag and lock open switches to avoid accidental closure.
- DO NOT CONNECT GENERATOR SET DIRECTLY TO ANY BUILDING ELECTRICAL SYSTEM. Hazardous voltages can flow from the generator set into the utility line. This creates a potential for electrocution or property damage. Connect only through an approved isolation switch or an approved paralleling device.

## **HIGH VOLTAGE GENERATOR SETS (1.9kV to 15kV)**

- High voltage acts differently than low voltage. Special equipment and training is required to work on or around high voltage equipment. Operation and maintenance must be done only by persons trained and qualified to work on such devices. Improper use or procedures will result in severe personal injury or death.
- Do not work on energized equipment. Unauthorized personnel must not be permitted near energized equipment. Due to the nature of high voltage electrical equipment, induced voltage remains even after the equipment is disconnected from the power source. Plan the time for maintenance with authorized personnel so that the equipment can be de-energized and safely grounded.

## **GENERAL SAFETY PRECAUTIONS**

- Coolants under pressure have a higher boiling point than water. DO NOT open a radiator or heat exchanger pressure cap while the engine is running. Allow the generator set to cool and bleed the system pressure first.
- Benzene and lead, found in some gasoline, have been identified by some state and federal agencies as causing cancer or reproductive toxicity. When checking, draining or adding gasoline, take care not to ingest, breathe the fumes, or contact gasoline.
- Used engine oils have been identified by some state or federal agencies as causing cancer or reproductive toxicity. When checking or changing engine oil, take care not to ingest, breathe the fumes, or contact used oil.
- Provide appropriate fire extinguishers and install them in convenient locations. Consult the local fire department for the correct type of extinguisher to use. Do not use foam on electrical fires. Use extinguishers rated ABC by NFPA.
- Make sure that rags are not left on or near the engine.
- Remove all unnecessary grease and oil from the unit. Accumulated grease and oil can cause overheating and engine damage which present a potential fire hazard.
- Keep the generator set and the surrounding area clean and free from obstructions. Remove any debris from the set and keep the floor clean and dry.
- Do not work on this equipment when mentally or physically fatigued, or after consuming any alcohol or drug that makes the operation of equipment unsafe.
- Substances in exhaust gases have been identified by some state or federal agencies as causing cancer or reproductive toxicity. Take care not to breath or ingest or come into contact with exhaust gases.

**KEEP THIS MANUAL NEAR THE GENSET FOR EASY REFERENCE**

# 1. Introduction

---

## GENERAL

Each operator should read this manual before operating the set for the first time. A generator set must be operated and maintained properly if you are to expect safe, reliable and quiet operation. The manual includes a troubleshooting guide and a maintenance schedule.

The engine manual is included with the set. Where there is conflicting information, this manual takes precedence over the engine manual.

**⚠ WARNING** *Improper operation and maintenance can lead to severe personal injury or loss of life and property by fire, electrocution, mechanical breakdown or exhaust gas asphyxiation. Read the safety precautions inside the front cover and carefully observe all instructions and precautions in this manual.*

## HOW TO OBTAIN SERVICE

When the generator set requires servicing, contact your nearest Cummins®/Onan® dealer or distributor. Factory-trained Parts and Service representatives are ready to handle all your service needs.

If you are unable to locate a dealer or distributor, consult the Yellow Pages. Typically, our distributors are listed under:

GENERATORS-ELECTRIC or  
ELECTRICAL PRODUCTS

For the name of your local Cummins/Onan or Onan-only distributor in the United States or Canada, call 1-800-888-ONAN (this automated service utilizes touch-tone phones only). By entering your area code and the first three digits of your local telephone number, you will receive the name and telephone number of the distributor nearest you.

For outside North America, call Onan Corporation, 1-612-574-5000, 7:30 AM to 4:00 PM, Central Standard Time, Monday through Friday. Or, send a fax to Onan using the fax number 1-612-574-8087.

When contacting your distributor, always supply the complete Model, Specification, and Serial Number as shown on the generator set nameplate.

### **⚠ WARNING**

**INCORRECT SERVICE OR PARTS REPLACEMENT CAN RESULT IN SEVERE PERSONAL INJURY, DEATH, AND/OR EQUIPMENT DAMAGE. SERVICE PERSONNEL MUST BE QUALIFIED TO PERFORM ELECTRICAL AND/OR MECHANICAL SERVICE.**

Onan is a registered trademark of Onan Corporation.

Cummins is a registered trademark of Cummins Engine Company, Inc.

## 2. Specifications

---

MODEL	EK	EM
<b>Engine</b> Onan Modified Ford In-line 6	CSG-649	CSG-649
<b>Generator Rating</b> 3-Phase, 60Hz (kVA @ 0.8 PF) 3-Phase, 50 Hz (kVA @ 0.8 PF)	35 kW (44 kVA) 30 kW (38 kVA)	45 kW (56 kVA) 37 kW (46 kVA)
<b>Electrical System</b> Starting Voltage Battery Charging Current	12V 65 amp	12V 65 amp
<b>Cooling System</b> Coolant Capacity with Standard Radiator	5 gal (19 L)	5 gal (19 L)
<b>Lubricating System</b> Oil Capacity with Filter	7 qt (7 L)	7 qt (7 L)
<b>Fuel or a combination of two fuels</b>	Gasoline Propane Natural Gas	Gasoline Propane Natural Gas
<b>Tune-up Specs</b> Spark Plug Gap	.042 to .046 (1.05 to 1.15 mm)	.042 to .046 (1.05 to 1.15 mm)
<b>Battery</b> Required Battery Voltage SAE Number	12 VDC 60	12 VDC 60

# 3. Operation

---

## GENERAL

This section covers prestart checks, starting and stopping and operating the generator set. Each operator should read through this entire section before attempting to start the set. It is essential that the operator be completely familiar with the set for safe operation.

## PRESTART CHECKS

Before starting, be sure the following checks have been made and the unit is ready for operation. Refer to the *Maintenance* section for the recommended procedures.

### Lubrication

Check the engine oil level. Keep the oil level as close as possible to the dipstick high mark without overfilling.

### Coolant

Check the engine coolant level. The coolant should be about two inches (50 mm) below the radiator cap opening. Do not check while the engine is hot.

**⚠️WARNING** *Contact with hot coolant can result in severe burns. Do not bleed hot, pressurized coolant from a closed cooling system.*

### Fuel

Make sure the fuel tanks have sufficient fuel and that fuel system is primed.

## CONTROL PANEL

The following describes the function and operation of the standard Detector 7 and optional Detector 12 generator set control. All instruments and control switches are located on the face of the control panel as illustrated in Figures 3-1 through 3-3. The control panel is separated into a DC panel for monitoring the engine and an AC panel for monitoring the generator.

## EXHAUST GAS IS DEADLY!

***Exhaust gases contain carbon monoxide, an odorless and colorless gas. Carbon monoxide is poisonous and can cause unconsciousness and death. Symptoms of carbon monoxide poisoning can include:***

- ***Dizziness***
- ***Nausea***
- ***Headache***
- ***Weakness and Sleepiness***
- ***Throbbing in Temples***
- ***Muscular Twitching***
- ***Vomiting***
- ***Inability to Think Coherently***

***IF YOU OR ANYONE ELSE EXPERIENCE ANY OF THESE SYMPTOMS, GET OUT INTO THE FRESH AIR IMMEDIATELY. If symptoms persist, seek medical attention. Shut down the unit and do not operate until it has been inspected and repaired.***

***Protection against carbon monoxide inhalation includes proper installation and regular, frequent visual and audible inspections of the complete exhaust system.***

1-P/EM

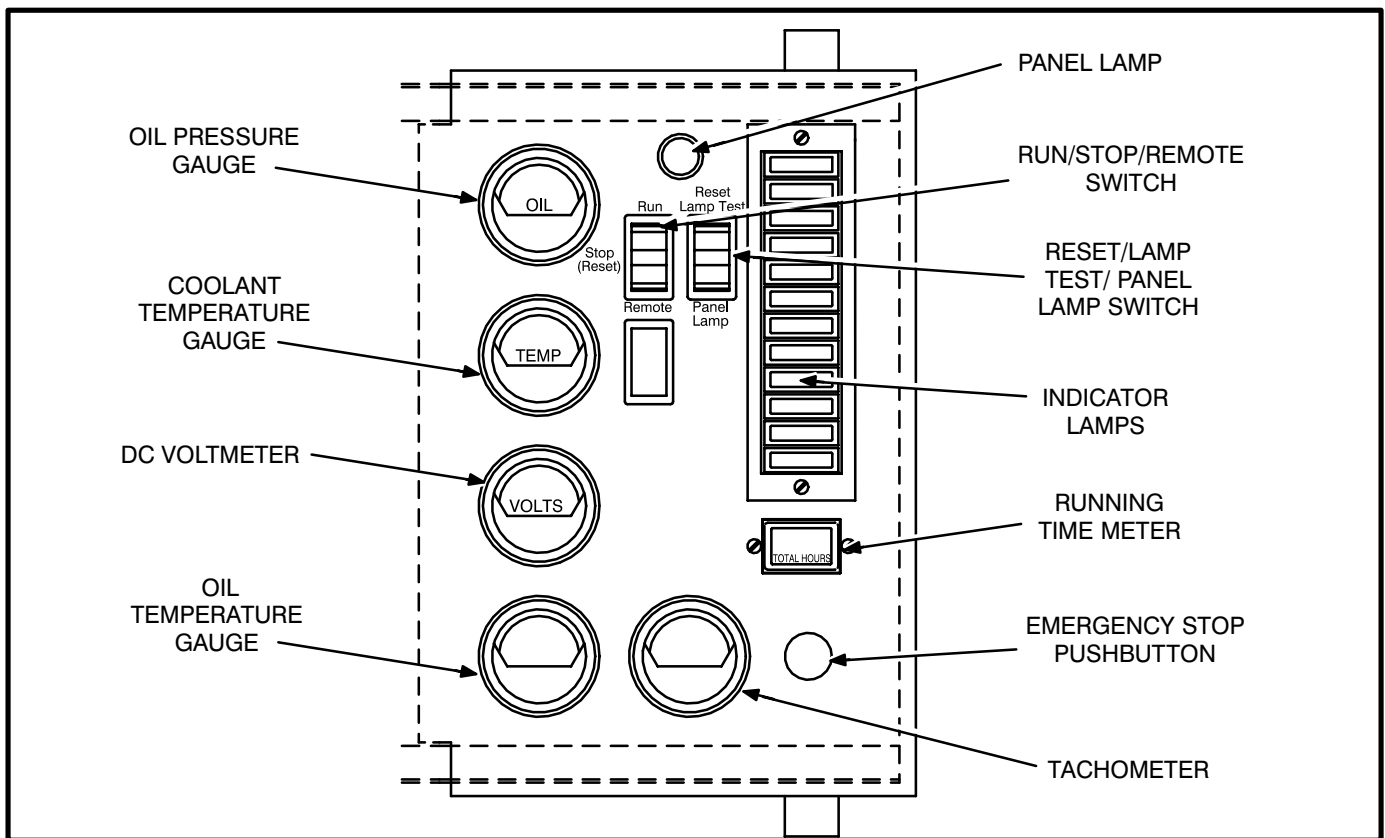

FIGURE 3-1. DC CONTROL PANEL (DETECTOR 12 SHOWN)

## DC Panel

**Panel Lamp:** Illuminates control panel.

**Oil Pressure Gauge:** Indicates pressure of lubricating oil in engine (wired to a sensor located on the engine).

**Coolant Temperature Gauge:** Indicates temperature of circulating coolant in engine (wired to a sensor located on engine).

**DC Voltmeter:** Indicates the battery charging system voltage.

**Run/Stop/Remote Switch:** Starts and stops the set locally, or from a remote location wired to the control engine monitor board.

**Running Time Meter:** Registers the total number of hours the unit has run. Use it to keep a record of periodic servicing. Time is cumulative; meter cannot be reset.

**Reset/Lamp Test/Panel Lamp Switch:** Resets the fault circuit only when the Run/Stop/Remote switch is in the Stop (Reset) position. Tests fault lamps and turns on the control panel lamp.

**Tachometer (Optional):** Provides constant monitoring of engine r/min.

**Oil Temperature Gauge (Optional):** Indicates temperature of lubricating oil in engine (wired to a sensor located on the engine).

**Emergency Stop Button (Optional):** Push-in switch for emergency shutdown of the engine. To reset, pull switch out and move Run/Stop/Remote switch to Stop position. Then push test switch to Reset/Lamp Test position.



**Detector 7 Indicator Lamps:** The standard control panel has seven indicator lamps which are described as follows:

- RUN (green) lamp comes on when starter circuit opens after set starting.
- PRE LO OIL PRES (yellow) indicates engine oil pressure is marginally low.
- PRE HI ENG TEMP (yellow) indicates engine temperature is marginally high.
- LO OIL PRES (red) indicates engine has shut down because of critically low oil pressure.
- HI ENG TEMP (red) indicates engine has shut down because of critically high engine temperature.
- OVERSPEED (red) indicates engine has shut down because of excessive speed.
- OVERCRANK (red) indicates engine has failed to start during the cranking period.

**Detector 12 Indicator Lamps:** The optional twelve lamp control includes all the features of the seven lamp control plus the following:

- FAULT 1 (red) lamp indicates an undedicated fault. May be field programmed as a shutdown or non-shutdown, and as a timed or non-timed fault. (Normally set for timed shutdown).
- FAULT 2 (red) lamp indicates same features as Fault 1 (normally set for non-timed shutdown).
- LOW ENG TEMP (yellow) lamp lights if engine temperature is marginally low for starting. It may indicate an inoperative coolant heater.
- LO FUEL (yellow) indicates fuel supply is marginally low.
- SWITCH OFF (flashing red) indicates generator set is not in automatic start mode.

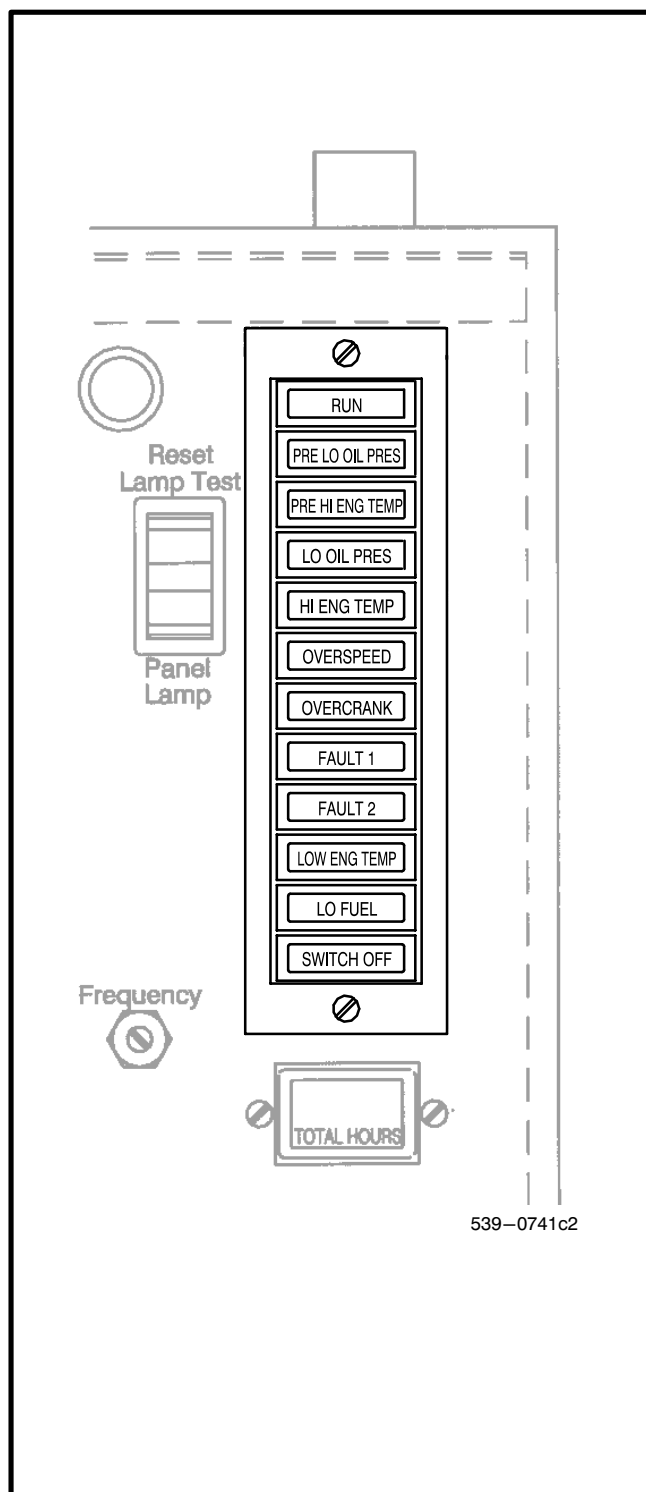

**FIGURE 3-2. INDICATOR LAMPS**

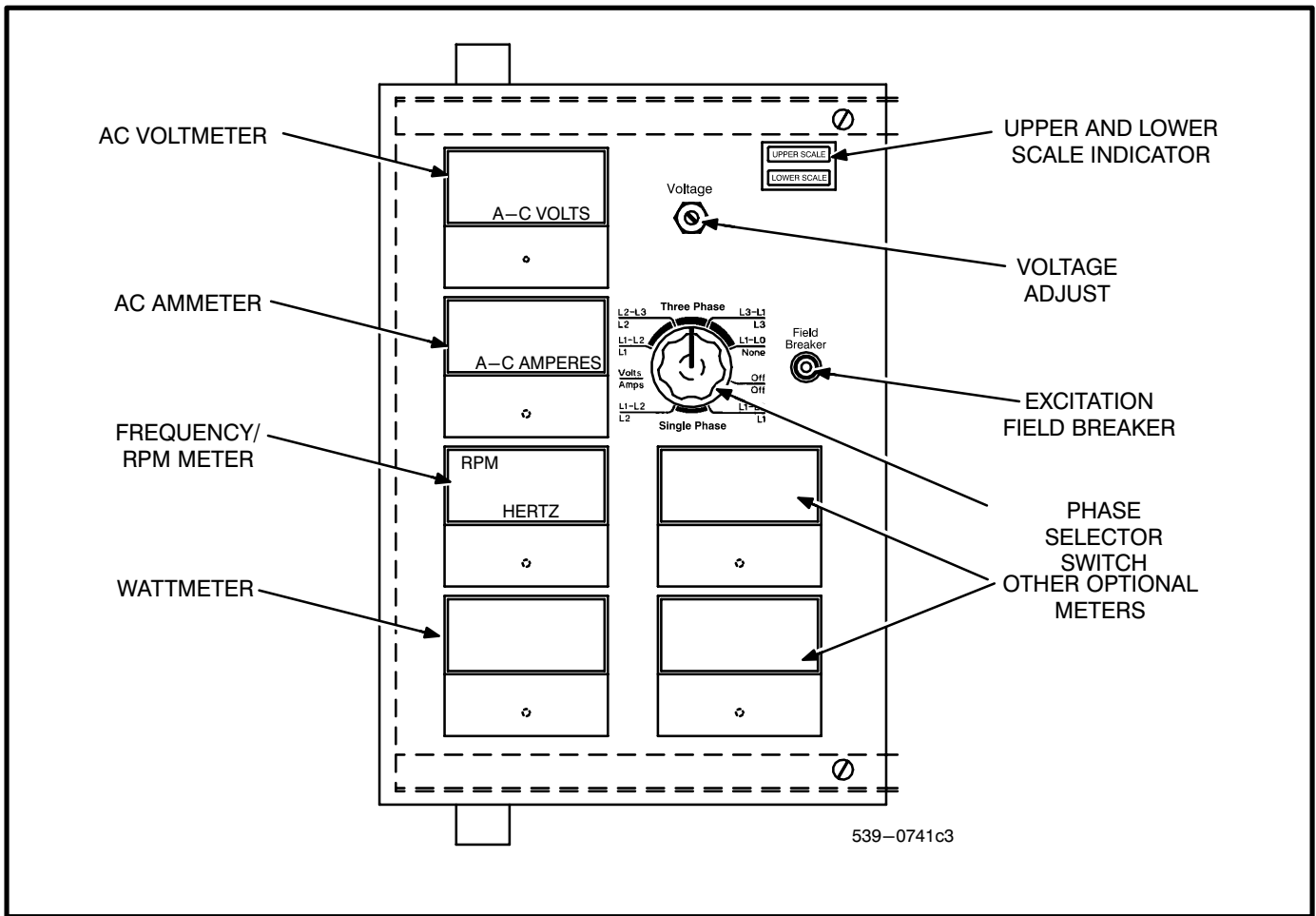

FIGURE 3-3. AC CONTROL PANEL

## AC Panel

**AC Voltmeter (Optional):** Dual range instrument indicating AC voltage. Measurement range in use shown on indicator lamp.

**AC Ammeter (Optional):** Dual range instrument indicates AC generator line current.

**Wattmeter (Optional):** Continuously gives reading of the generator output in kilowatts.

**Power Factor Meter (Optional):** Indicates percent power factor of AC output.

**Frequency/RPM Meter (Optional):** Indicates generator output frequency in hertz and engine speed in revolutions-per-minute (RPM).

**Voltage Adjusting Rheostat (Optional):** Provides approximately plus or minus five percent adjustment of the rated output voltage.

**Upper and Lower Scale Indicator Lamps (Optional):** Indicates which scale to use on the AC voltmeter and ammeter.

**Phase Selector Switch (Optional):** Selects phases of generator output to be measured by AC voltmeter and ammeter.

**Engine Pyrometers (Optional):** Indicate engine exhaust and inlet air temperatures.

**Field Breaker:** Provides generator exciter and regulator protection from overheating in the event of certain failure modes of generator, exciter and voltage regulator.

## GENERATOR AC VOLTAGE REGULATOR

The solid-state regulator controls AC output voltage from the generator at a predetermined level regardless of load. Voltage regulation is plus or minus two percent from no load to full load. Random voltage variation is plus or minus one percent for constant loads.

## ENGINE CONTROL MODULE

Electronic and relay components of the engine monitoring circuit are on a circuit board assembly. Sensor inputs are connected by the wiring harness to plug connectors on the board. The control module provides the following functions of unit protection.

- **Overcrank** - Limits engine cranking to 75 seconds. If engine fails to start, the module lights a fault lamp and opens the cranking circuit. The cycle cranking option allows three 15-second cranking cycles with two 15-second rest periods on the 12-lamp control.
- **Overspeed** - Shuts down the engine immediately if overspeed occurs and lights a fault lamp. The sensor switch is mounted in the end bell on the generator shaft. It is factory adjusted to shut down 60 hertz units at  $2100 \pm 90$  r/min, 50 hertz units at  $1850 \pm 50$  r/min.
- **Low Oil Pressure** - Shuts down the engine immediately if oil pressure drops below 14 psi (97 kPA) and lights a fault lamp. The fault is time-delayed about 10 seconds following starter disconnect and inhibited during cranking. The delay allows oil pressure to rise to normal before the electronic control module monitors this system.

A pre-low oil pressure sensor and lamp provides an alarm that oil pressure is marginally low, 20 psi (138 kPA) or less. The cause should be found and corrected as soon as possible.

- **High Engine Temperature** - shuts down the engine immediately if coolant temperature rises above 215° F (102° C) and lights a fault lamp. The fault is time-delayed about 10 seconds following starter disconnect and inhibited during cranking. This delay allows coolant in a hot engine time to circulate and return the water jacket to normal before the electronic control module monitors this system.

A pre-high engine temperature sensor and lamp provides an alarm that engine temperature is marginally high, 205° F (97° C). The cause should be found and corrected as soon as possible.

**⚠ CAUTION** *The high engine temperature shutdown system will not operate if the coolant level is too low. The high engine temperature sensor monitors coolant temperature. Loss of coolant will prevent sensor operation and allow the engine to overheat causing severe damage to the engine. Therefore, maintain adequate coolant level for proper operation of the high engine temperature shutdown system.*

- **Low Coolant Level (Optional)** – An electronic switch that is used to detect low coolant level. This switch may be connected in parallel with the high engine temperature cutout switch to shut down the engine and light the **High Engine Temperature** lamp or in parallel with the pre-high engine temperature switch to light the **Pre-High Engine Temperature** light only.

## STARTING

The following sections cover the three systems used to start the generator set.

### Starting at Control Panel

Move the Run-Stop-Remote switch on the DC panel to the RUN position. This will activate the engine control system and the starting system. The starter will begin cranking and after a few seconds the engine should start. The starter will disconnect when the engine reaches a speed of 450 to 570 RPM.

If the engine does not start, the starter will disengage after a specified period of time and the control will indicate an overcrank fault. Generator sets with the standard overcrank control will crank continuously for up to 75 seconds before disengaging the starter. Generator sets with the cycle cranking option will crank for 15 seconds in each cycle until 3 cycles have been completed. To clear an overcrank fault, place the Run-Stop-Remote switch in the STOP position and momentarily depress the Reset switch. Wait two minutes for the starter motor to cool and then repeat the starting procedure. If the engine does not run after a second attempt at starting, refer to the *Troubleshooting* section.

### Starting From Remote Location

Move the Run/Stop/Remote switch on the generator set DC panel to the REMOTE position. This al-

lows the generator set to be started from a remote switch. Closing the remote switch initiates the starting sequence described in the previous section.

### Automatic Starting

Place the Run/Stop/Remote switch on the generator set DC panel in the REMOTE position if an automatic transfer switch is used. This allows the transfer switch to start the generator set if a power outage occurs and stop it when the power returns.

### Start-Up Checks

Observe the oil pressure gauge after the engine is started. A normal oil pressure reading (at operating temperature) is between 35 to 60 psi (241 to 414 kPa). The following gauges should also be checked for normal readings:

- DC Ammeter – Normal charging rate is 1 to 15 amperes depending on battery state of charge.
- AC Voltmeter – Generator output voltage should be stable and not vary more than  $\pm 1\%$  of the rated value while under load.
- Frequency Meter – Generator frequency should be stable.
- Water Temperature – Run the generator set for about 10 minutes and then check the water temperature gauge. The engine should stabilize between 180 to 195° F (83 to 91° C).

## STOPPING

### Before Stopping

Run the generator set at no load for three to five minutes before stopping. This allows the lubricating oil and engine coolant to carry heat away from the combustion chamber and bearings.

### To Stop

If the set was started at the set control panel or at a remote control panel, move the Run/Stop/Remote switch or remote starting switch to the STOP position. If the set was started by an automatic transfer switch, the set will automatically stop about 15 minutes after the normal power source returns.

### Emergency Stop

An optional emergency stop button is located on the right side of control panel (Figure 3-1). Push button in for emergency stop. To reset, pull switch out and move Run/Stop/Remote switch to Stop position. Then push test switch to Reset/Lamp Test position.

## BREAK-IN

Drain and replace the crankcase oil after the first 50 hours of operation on new generator sets.

## NO-LOAD OPERATION

Periods of no load operation should be held to a minimum. If it is necessary to keep the engine running for long periods of time when no electric output is required, best engine performance will be obtained by connecting a “dummy” electrical load. Such a load could consist of heater element, etc.

## EXERCISE PERIOD

Generator sets on continuous standby must be able to go from a cold start to being fully operational in a matter of seconds. This can impose a severe burden on engine parts.

Regular exercising keeps engine parts lubricated, prevents oxidation of electrical contacts and in general helps provide reliable engine starting. Exercise the generator set at least once a week for a minimum of 30 minutes with load so the engine reaches normal operating temperatures.

Onan automatic transfer switches have as an option an exerciser that can be preset to provide regular exercise periods. Typically the exerciser can be set for time of start, length of run, and day of week.

If it is necessary to start the set on natural gas, the choke must be adjusted to the fully open position before the set will start. Make a mark on the choke housing to indicate the position of the choke cover index pointer. Loosen the three choke cover screws (Figure 6-2) and rotate the choke cover counterclockwise approximately 90 degrees. Tighten the three choke cover screws and place the fuel selector switch in the GAS position. The set may now be started on natural gas.

## HIGH/LOW OPERATING TEMPERATURES

Use a coolant heater if a separate source of power is available. The optional heater available from Onan will help provide reliable starting under adverse weather conditions. Be sure the voltage of the separate power source is correct for the heater element rating.

**⚠ CAUTION** *To avoid damage to heater, be sure the cooling system is full before applying power to the heater.*

## POWER RATING FACTORS

The generator set power rating applies to sets used in standby applications. The set will operate at the stated rating for the duration of normal utility power interruptions. The rating was established for a standard radiator cooled set operating at an altitude of 300 feet (92 m) with an ambient temperature of 81°F (27°C). For a rating relative to other applications, altitudes, cooling systems, or ambient temperatures, contact your authorized distributor.

# 4. Troubleshooting

---

The generator set has sensors that continuously monitor the engine for abnormal conditions, such as low oil pressure or high coolant temperature. If these conditions occur, the engine monitor activates a fault lamp, and may also stop the engine (depending on the condition). If the generator set is stopped for this reason, the operator may be able to restart the set after making adjustments or corrections. This section describes the fault condition system, and suggests troubleshooting procedures.

The standard seven-light control has a single green light to indicate RUN, two amber pre-fault lights and four red fault lights. The optional twelve-light control has a single green light to indicate RUN, four amber lights and seven red fault lights. Both controls also have a terminal connection for a remote audible alarm, which sounds when a fault occurs.

## SAFETY CONSIDERATIONS

High voltages are present inside the control box and generator output box when the set is running. Do not open the control box or generator output box while the set is running.

**⚠WARNING** *Contacting high voltage components can cause severe personal injury or death. Keep control and output box covers in place during troubleshooting.*

When troubleshooting a set that is shut down, make certain the generator set cannot be accidentally re-

started. Place the Run/Stop/Remote switch in the STOP position. Turn off or remove AC power from the battery charger and then remove the negative battery cable from the set starting battery.

**⚠WARNING** *Accidental starting of the generator set during troubleshooting can cause severe personal injury or death. Disable the generator set before troubleshooting.*

When a fault lamp turns on during operation, follow the procedures listed below to locate and correct the problem. For any symptom not listed, contact an authorized service center for assistance.

## Resetting the Control

The external alarm and fault lamp may be deactivated by moving the Run/Stop/Remote switch to the Stop position and pressing the Reset/Lamp Test switch. Locate the problem and correct it before re-starting the set. While pressing the Reset/Lamp Test switch, make certain that all lamps light.

## Line Circuit Breaker (Optional)

The optional line circuit breaker mounts on the generator output box. If the load exceeds the generator current rating, the line circuit breaker will open, preventing the generator from being overloaded. If the circuit breaker trips, locate the source of the overload and correct as necessary. Manually reset the breaker to reconnect the load to the generator.

**TABLE 4-1. TROUBLESHOOTING**

**⚠WARNING** *Many troubleshooting procedures present hazards which can result in severe personal injury or death. Only qualified service personnel with knowledge of fuels, electricity, and machinery hazards should perform service procedures. Review safety precautions on pages ii and iii.*

SYMPTOM	CORRECTIVE ACTION
1. Green RUN lamp lights following engine startup.	1. Indicates all engine systems are normal. No corrective action required.
2. PRE HI ENGINE TEMP lamp lights. Engine continues to operate.	<p>2. Indicates engine has begun to overheat and engine temperature has risen to approximately 205° F (97° C). If generator is powering non-critical and critical loads and cannot be shut down, use the following:</p> <ul style="list-style-type: none"> <li>a. Reduce load if possible by turning off non-critical loads.</li> <li>b. Check air inlets and outlets and remove any obstructions to airflow.</li> </ul> <p>If engine can be stopped, follow procedure in step 3.</p>
3. HI ENG TEMP lamp lights. Engine shuts down.	<p>3. Indicates engine has overheated (engine temperature has risen above 215° F/102° C) or coolant level is low (sets with coolant level sensor). Allow engine to cool down completely before proceeding with the following checks:</p> <ul style="list-style-type: none"> <li>a. Check coolant level and replenish if low. Look for possible coolant leakage points and repair if necessary.</li> <li>b. Check for obstructions to cooling airflow and correct as necessary.</li> <li>c. Check for a slipping fan belt and tighten if loose.</li> <li>d. Reset control and restart after locating and correcting problem. Contact an authorized service center if none of the above.</li> </ul>
4. PRE LO OIL PRES lamp lights. Engine continues to operate.	4. Indicates engine oil pressure has dropped to 20 psi (138 kPa). If generator is powering critical loads and cannot be shut down, wait until next shutdown period and then follow step 5 procedure. If engine can be stopped, follow procedures in step 5.
5. LO OIL PRES lamp lights. Engine shuts down. NOTE: See also step 6.	5. Indicates engine oil pressure has dropped to 14 psi (97 kPa). Check oil level and filters. If oil system is OK but oil level is low, replenish. Reset control and restart. Contact an authorized service center if oil pressure is not in the range of 35 to 60psi (241 to 414 kPa).



**TABLE 4-1. TROUBLESHOOTING (continued)**

**⚠WARNING** Many troubleshooting procedures present hazards which can result in severe personal injury or death. Only qualified service personnel with knowledge of fuels, electricity, and machinery hazards should perform service procedures. Review safety precautions on pages ii and iii.

SYMPTOM	CORRECTIVE ACTION
<p>6. OVERCRANK lamp lights and engine stops cranking.</p> <p>or</p> <p>Engine runs, shuts down, and LO OIL PRES lamp lights..</p>	<p>6. Indicates possible fuel or ignition system problem.</p> <ul style="list-style-type: none"> <li>a. Check for empty fuel tank, fuel leaks, or plugged fuel lines and correct as required.</li> <li>b. Check for dirty fuel filter and replace if necessary (see MAINTENANCE section).</li> <li>c. Check for dirty or plugged air filter and replace if necessary (see MAINTENANCE section).</li> <li>d. Check ignition system (see MAINTENANCE).</li> <li>e. Reset the control and restart after correcting the problem. Contact an authorized service center for service if none of the above.</li> </ul>
<p>7. Engine runs and then shuts down, OVER-SPEED lamp lights.</p>	<p>7. Indicates engine has exceeded normal operating speed. Contact an authorized service center for service.</p>
<p>*8. SWITCH OFF lamp flashes.</p>	<p>8. Indicates Run/Stop/Remote switch is in the Stop position which will prevent automatic starting if an automatic transfer switch is used. Move the Run/Stop/Remote switch to the Remote position for automatic starting.</p>
<p>*9. LO FUEL lamp lights. Engine continues to run.</p>	<p>9. Indicates gasoline fuel supply is running low. Check fuel supply and replenish as required.</p>
<p>*10. LO FUEL LAMP lights. Engine shuts down and LO OIL PRES lamp lights.</p>	<p>10. Indicates engine has run out of fuel. Check fuel level and replenish as required.</p>
<p>*11. LO ENG TEMP lamp lights. Set is in standby mode but is not operating.</p> <p>(Lamp lights when engine coolant temperature is 70° F (21° C) or lower. Since the lamp goes out after the engine warms up, there should be no cause for alarm even during initial generator set operation.)</p>	<p>11. Indicates engine coolant heater is not operating or is not circulating coolant. Check for the following conditions:</p> <ul style="list-style-type: none"> <li>a. Coolant heater not connected to power supply. Check for blown fuse or disconnected heater cord and correct as required.</li> <li>b. Check for low coolant level and replenish if required. Look for possible coolant leakage points and repair as required.</li> <li>c. Contact an authorized service center if none of the above.</li> </ul>

\* 12-Light Panel Only.

NOTE: LO FUEL LAMP not applicable on natural gas or propane units.



**TABLE 4-1. TROUBLESHOOTING (continued)**

**⚠WARNING** *Many troubleshooting procedures present hazards which can result in severe personal injury or death. Only qualified service personnel with knowledge of fuels, electricity, and machinery hazards should perform service procedures. Review safety precautions on pages ii and iii.*

SYMPTOM	CORRECTIVE ACTION
*12. The FAULT 1 or FAULT 2 fault lamp lights. Engine shuts down immediately, engine runs for several seconds and then shuts down, or engine continues to run.	12. The standard undesignated fault functions are programmed to shut down the set when a fault is sensed. Fault 1 is time delayed while Fault 2 is immediate. The nature of the fault is an optional selection that is determined when the set installation is designed. the undesignated fault functions may also be programmed for non-shutdown or non-time delay.
13. Fault lamp lights but no fault exists. Engine gauges show oil pressure, engine temperature, and frequency (speed) are within normal limits.	13. The monitor board or a sensor may be at fault. Contact an authorized service center for service.
14. Engine starts from generator control panel but will not start automatically or from a remote panel. (Note: The Run/Stop/Remote switch must be in the Remote position for automatic or remote starting).	14. Remote circuit breaker is tripped. Reset breaker and re-start. Contact an authorized service center if breaker trips after resetting.
15. Engine will not crank.	15. Indicates possible fault with control or starting system. Check for the following conditions:  a. Fault lamp on. Correct fault and reset control.  b. Poor battery cable connections. Clean the battery cable terminals and tighten all connections.  c. Discharged or defective battery. Recharge or replace the battery.  d. Contact an authorized service center for assistance if none of the above.
16. No AC output voltage.	16. Field breaker is tripped. Reset breaker. Contact an authorized service center if voltage buildup causes breaker to trip.
17. Green RUN lamp does not light following engine startup.	17. Indicates possible Start/Disconnect relay failure. Contact an authorized service center for assistance.

\* 12-Light Panel Only.

# 5. Maintenance

## MAINTENANCE

Establish and adhere to a definite schedule for maintenance and service based on the application and severity of the environment. The table below covers the recommended service intervals for a generator set on STANDBY service. If the set will be subjected to extreme operating conditions, the service intervals should be reduced accordingly. Some of the factors that can affect the maintenance schedule are the following:

- Use for continuous duty (prime power)
- Extremes in ambient temperature
- Exposure to elements
- Exposure to salt water
- Exposure to windblown dust or sand.

Consult with an authorized Onan Distributor if the generator set will be subjected to any extreme operating conditions and determine a suitable schedule of maintenance. Use the running time meter to keep an accurate log of all service performed for warranty support. Perform all service at the time period indicated or after the number of operating hours indicated, whichever comes first. Use Table 5-1 to determine the maintenance required and then refer to the sections that follow for the correct service procedures.

**⚠️WARNING** *Accidental starting of the set while performing maintenance procedures can cause serious personal injury or death. Place the Run-Stop-Remote switch in the Stop position, disconnect battery charger from its AC source and disconnect the negative(-) battery cable from the battery terminal before beginning maintenance procedures.*

**TABLE 5-1. PERIODIC MAINTENANCE SCHEDULE**

MAINTENANCE ITEMS	OPERATIONAL HOURS			
	10	100	200	300
Inspect complete set for leaks, etc.	x1			
Check engine oil level	x1			
Check radiator coolant level	x1			
Check air cleaner (clean or replace as necessary)		x2		
Check battery electrolyte level		x3		
Check and lubricate governor linkage		x2		
Change engine oil and filter		x2		
Check all hardware (fittings, clamps, fasteners, etc.)		x4		
Adjust drive belt tension			x5	
Inspect or replace spark plugs			x	
Inspect coolant heater hoses			x6	
Check AC generator and controls			x	
Replace Fuel filter Assembly			x2	
Check governor frequency setting				x

- x1 - As noted or after every run.
- x2 - Perform more often in extremely dusty conditions
- x3 - Or every two weeks.
- x4 - Or every three months.
- x5 - Adjust to 1/2-inch (12.5 mm) depression between pulleys.
- x6 - Replace if hard or brittle.

## GENERATOR SET INSPECTION

During operation, be alert for mechanical problems that could create unsafe or hazardous conditions. The following sections cover several areas that should be frequently inspected for continued safe operation.

### Exhaust System

With the generator set operating, inspect the entire exhaust system visually and audibly, including the exhaust manifold, muffler, and exhaust pipe. Check for leaks at all connections, welds, gaskets, and joints and also make sure that exhaust pipes are not heating surrounding areas excessively. If any leaks are detected, shut down the generator set and have leaks corrected immediately.

**⚠️WARNING** *Inhalation of exhaust gases can result in serious personal injury or death. Be sure deadly exhaust gas is piped outside and away from windows, doors or other inlets to building.*

### Fuel System

With the generator set operating, inspect the fuel supply lines, filters, and fittings for leaks. Check any flexible sections for cuts, cracks and abrasions and make sure they are not rubbing against anything that could cause breakage. If any leaks are detected, shut down generator set and have them corrected immediately.

**⚠️WARNING** *Ignition of fuel can cause severe personal injury or death by fire or explosion. Do not permit any flame, cigarette, pilot light, arcing switch or equipment, or other ignition source near the fuel system.*

### AC Electric System

Check the following while the generator set is operating; otherwise measure load lines L1, L2 and L3 using the appropriate AC meter.

**Frequency Meter:** The generator frequency should be stable and the reading should be the same as the nameplate rating.

**AC Voltmeter:** Turn the phase selector switch to each line-to-line phase selection shown on the volts scale (L1-L2, L2-L3, and L3-L1). Read the AC volt-

meter using the upper or lower scale as indicated by the scale indicator light. At no load, the line-to-line voltage(s) should be the same as the set nameplate rating.

**AC Ammeter:** Turn the phase selector switch to each phase selection shown on the amps scale (L1, L2 and L3). Read the ammeter using the upper or lower scale as indicated by the scale indicator light. At no load, the current readings should be zero. With a load applied, each line current should be about the same.

**Fault Lamps (Seven or Twelve Lamp Panels):** Push the Reset/Lamp switch on the control panel. All indicator lamps should light. Verify that all of the bulbs are on, then release the switch. Have any bulbs that are burned out replaced.

### DC Electrical System

Check the terminals on the battery for clean and tight connections. Loose or corroded connections create resistance which can hinder starting. Clean and reconnect the battery cables if loose. Always disconnect both ends of the negative battery cable. Reconnect one end of the cable to the negative battery terminal and the other end to ground. Following this sequence will help to reduce arcing at the battery.

**⚠️WARNING** *Ignition of explosive battery gases can cause severe personal injury. Do not smoke while servicing batteries.*

**⚠️WARNING** *Accidental starting of the generator set can cause severe personal injury or death. Place the control switch in STOP position, disconnect battery charger from its AC source and disconnect the negative battery cable before inspecting generator set.*

### Mechanical

With the generator set stopped, check for loose belts and fittings, leaking gaskets and hoses, or any signs of mechanical damage. If any problems are found, have them corrected immediately. With the set running, listen for any unusual noises that may indicate mechanical problems and check the oil pressure frequently. Investigate anything that indicates possible mechanical problems.

## LUBRICATION SYSTEM

Before the initial start, check dipstick to be sure crankcase is filled with oil. See *Specifications* section for lubricating oil capacity.

**Generator sets are shipped with oil and coolant added. Be sure to check these systems to make sure they are at proper operating levels before starting.**

### Oil Recommendations

Refer to Figure 5-1 for the recommended oil viscosity grades at various ambient temperatures. Oils must conform to the American Petroleum Institute (API) classification SH or SH/CD. When selecting the oil viscosity, pick the grade that is right for the lowest temperature expected. Oil that is too thick can result in a lack of lubrication when the engine is started. Use a lower grade of oil as the ambient temperature reaches the lower end of the scale.

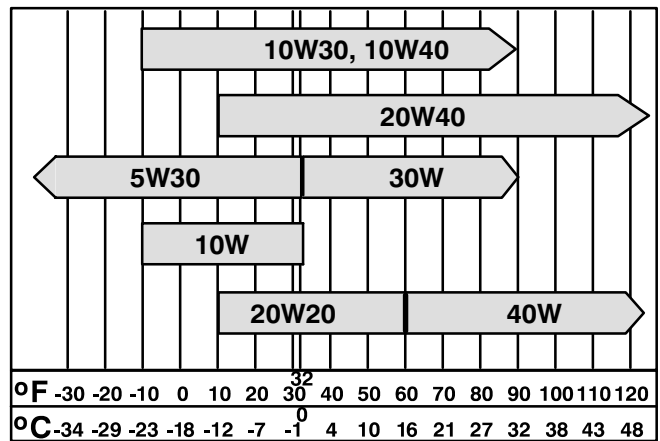

FIGURE 5-1. OIL VISCOSITY

## Engine Oil Level

Check the engine oil level during engine shutdown periods at the intervals specified in the Maintenance Table. The dipstick is stamped with FULL and ADD to indicate the level of oil in the crankcase. For accurate readings, shut off the engine and wait approximately 10 minutes before checking the engine oil level. This allows oil in the upper portion of the engine to drain back into the crankcase.

Keep the oil level as near as possible to the FULL mark on the dipstick. Remove the oil fill cap and add oil of the same quality and brand when necessary.

**CAUTION** Do not operate the engine with the oil level below the ADD mark or above the FULL mark. Overfilling can cause foaming or aeration of the oil. Operation below the ADD mark can cause loss of oil pressure.

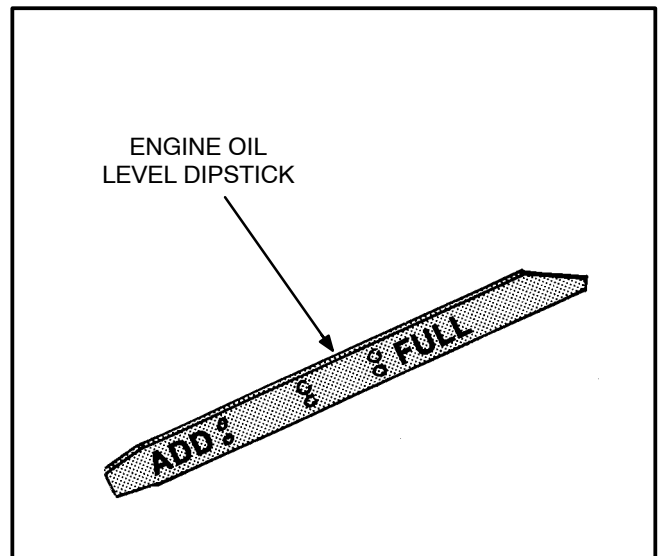

FIGURE 5-2. OIL LEVEL DIPSTICK

## Engine Oil Change

Run engine until thoroughly warm before draining oil. Stop the set, place a pan under the drain outlet and remove the oil drain plug or open the drain valve. After the oil is completely drained, replace the drain plug or close the drain valve. Refill with oil of the correct API viscosity grade for the temperature conditions.

**WARNING** Hot crankcase oil can cause burns if it is spilled or splashed on skin. Keep fingers and hands clear when removing the oil drain plug and wear protective clothing.

## Oil Filter Change

Spin off oil filter and discard it in accordance with local environmental regulations. Thoroughly clean filter mounting surface. Apply a thin film of oil to filter gasket and install new element. Spin element on by hand until gasket just touches mounting pad and then turn an additional 1/2 to 3/4 turn. Do not over-tighten (Figure 5-3).

With oil in crankcase, start engine and check for leaks around filter element. Retighten only as much as necessary to eliminate leaks but do not over-tighten.

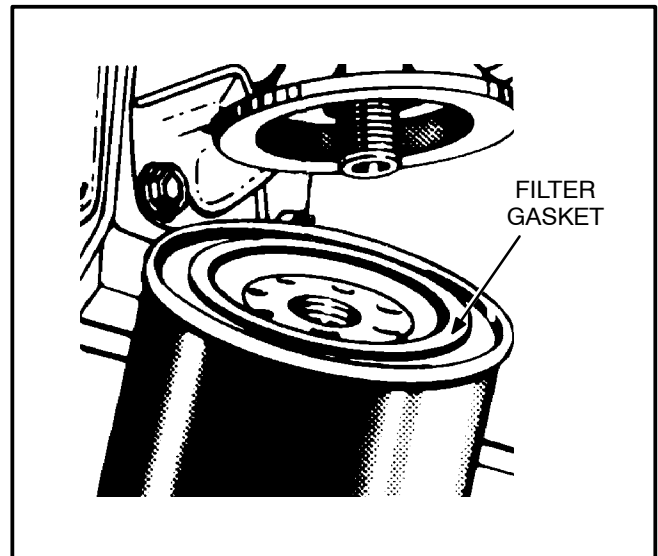

FIGURE 5-3. ENGINE OIL FILTER

## COOLING SYSTEM

The cooling system capacity of a standard unit with set mounted radiator is shown in Specifications section.

**Generator sets are shipped with oil and coolant added. Be sure to check these systems to make sure they are at proper operating levels before starting.**

### Coolant Requirements

Satisfactory engine coolant inhibits corrosion and if necessary protects against freezing. In warm weather climates where there is no danger of freezing, use a mixture of 35% antifreeze and 65% water as the coolant. In cold weather, use a 50/50 mixture of water and antifreeze. If temperatures below -37F (-38C) are possible, use a mixture of 65% antifreeze and 35% water.

The water used for engine coolant should be clean, low in mineral content and free of any corrosive chemicals such as chloride, sulfate or acid. Use soft water whenever available. Well water often contains lime and other materials which eventually can clog the radiator core and reduce the cooling efficiency.

### Filling the Cooling System

Verify that all drain cocks are closed and all hose clamps secure. Remove the radiator pressure cap and slowly fill the cooling system with the recommended coolant.

**CAUTION** *Never pour hot water into a cold engine or cold water into a hot engine. Doing so can crack a head or cylinder block. Do not operate the generator sets without water for even a few minutes.*

When the engine is first started, remove the pressure cap and monitor the coolant level. As trapped air is expelled from the system, the coolant level will drop and additional coolant must be added. Replace the pressure cap when the coolant level is stable.

### Coolant Level

Check the coolant level during shutdown periods at the intervals shown in Table 5-1. Remove the radiator cap after allowing the engine to cool and if necessary, add coolant until the level is near the top of the radiator.

**WARNING** *The sudden release of pressure from a heated cooling system can result in a loss of coolant and severe injury from the hot coolant. Allow the engine to cool and then slowly remove the radiator pressure cap.*

**CAUTION** *High Engine Temperature Cutoff will shut down engine in an overheat condition only if coolant level is sufficiently high to physically contact shutdown switch. Loss of coolant will allow engine to overheat without protection of shutdown device, thereby causing severe damage to the engine. Maintain adequate coolant level to provide operational integrity of cooling system and engine coolant overheat shutdown protection.*

## Draining and Flushing

To maintain adequate corrosion protection and remove rust and scale deposits, drain and flush radiator at the recommended interval. Allow the engine to cool and then remove radiator pressure cap. Open the radiator drain cock and remove the water jacket plugs (one on each side of engine). When the coolant is drained, place the end of a water hose into the radiator filler and turn on water supply. Regulate the flow of water into the radiator until it is equal to the outflow from drain openings. Continue flushing until outflow from drains is clear of rust sediment.

**If engine is equipped with water jacket heater, drain coolant by opening valve on bottom of heater.**

Replace the water jacket plugs and close the radiator drain cock when flushing is complete. Refill the cooling system with the recommended coolant.

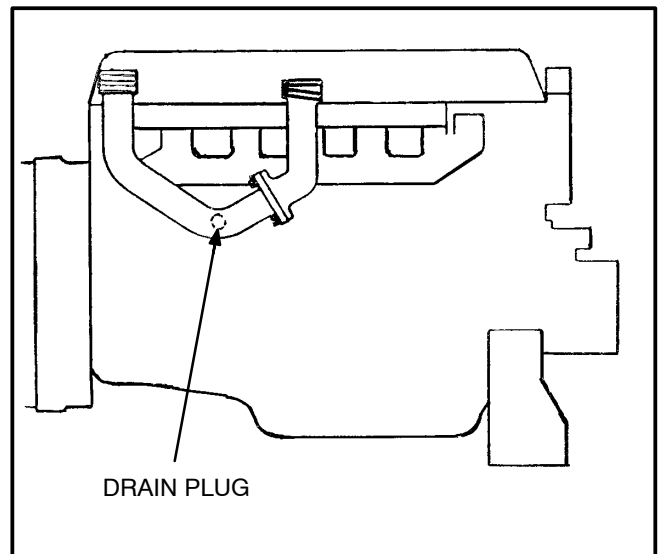

FIGURE 5-4. WATER JACKET DRAIN

## AIR FILTER

Remove wing nut in center of filter cover (Figure 5-5). Remove cover and filter. Tap filter on a flat surface to remove dirt. Place a light source inside filter and inspect for air passage. If necessary, apply a low pressure air source (30 psi) to the inside of filter to remove as much dirt as possible. Inspect interior housing. Vacuum clean if dirty or remove housing and wipe clean.

**⚠ CAUTION** *Do not clean filter housing while still installed. Loose dirt entering intake could damage carburetor or engine.*

Clean air filter every 100 hours of operational time, more often in extremely dusty conditions. Replace air filter after 500 hours of operational time.

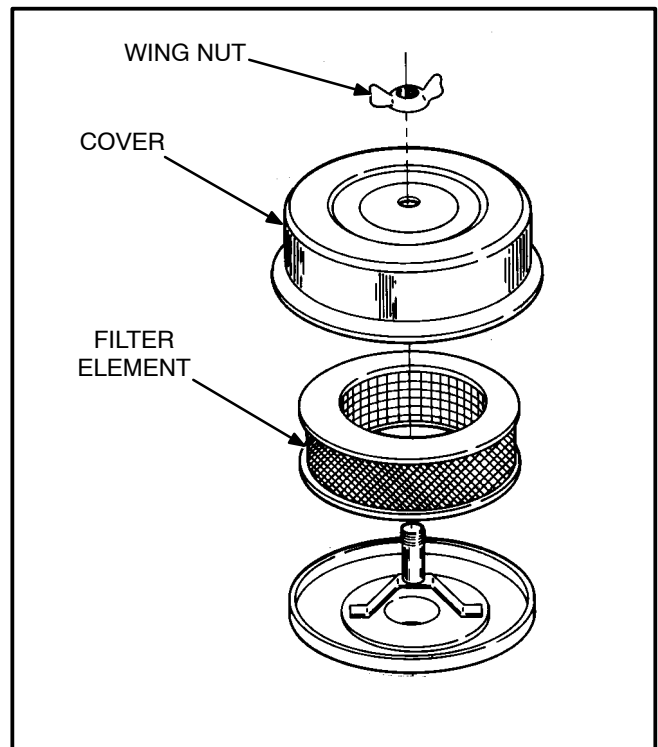

FIGURE 5-5. TYPICAL AIR CLEANER



## FUEL FILTER (GASOLINE SETS)

Replace filter every 200 operational hours or as conditions require. Unscrew the filter housing from the fuel pump (Figure 5-6) and remove the filter element and gasket. Discard the element and gasket. Clean the filter housing in a petroleum cleaning solvent.

**⚠WARNING** Ignition of fuel can cause severe personal injury or death by fire or explosion. When working on fuel system components, do not permit any flame, cigarette, pilot light, arcing switch or equipment, or other ignition source in the area or areas sharing ventilation.

Place a new filter element over the spout in the fuel pump valve housing cover. Be sure to use the proper type element for the installation.

Coat a new gasket with a light engine oil and position the gasket on the filter housing. Screw the filter housing onto the fuel pump. Hand tighten the filter housing until the gasket contacts the pump, and then advance it 1/8 turn. Start the engine and check for leaks.

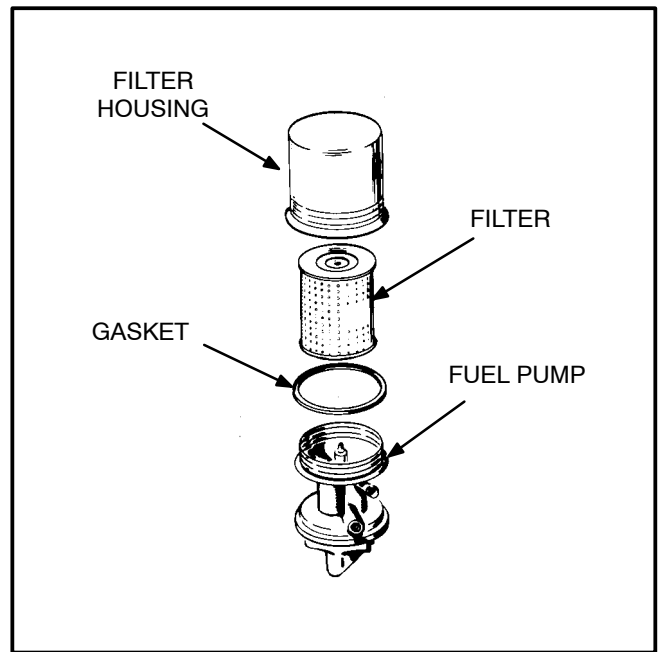

FIGURE 5-6. TYPICAL AIR CLEANER

## DRIVE BELTS

Two separate belts are used to drive the fan, water pump and alternator (Figure 5-7). Check the drive belts at the recommended interval. Remove the belt guard and inspect each belt for cracks, fraying, or glazing. Replace when necessary.

To adjust the fan belt, loosen fan bracket screws, then move bracket up or down until a deflection of 0.50 inch (13 mm) is obtained between crankshaft pulley and fan pulley by applying a force of 10 pounds to the midpoint of the belt.

To adjust the alternator belt, loosen link clamp screw and the mounting bolts. Move alternator toward or away from engine until a deflection of 0.50 inch (13 mm) is obtained between pulleys by applying a force of 10 pounds to the midpoint of the belt.

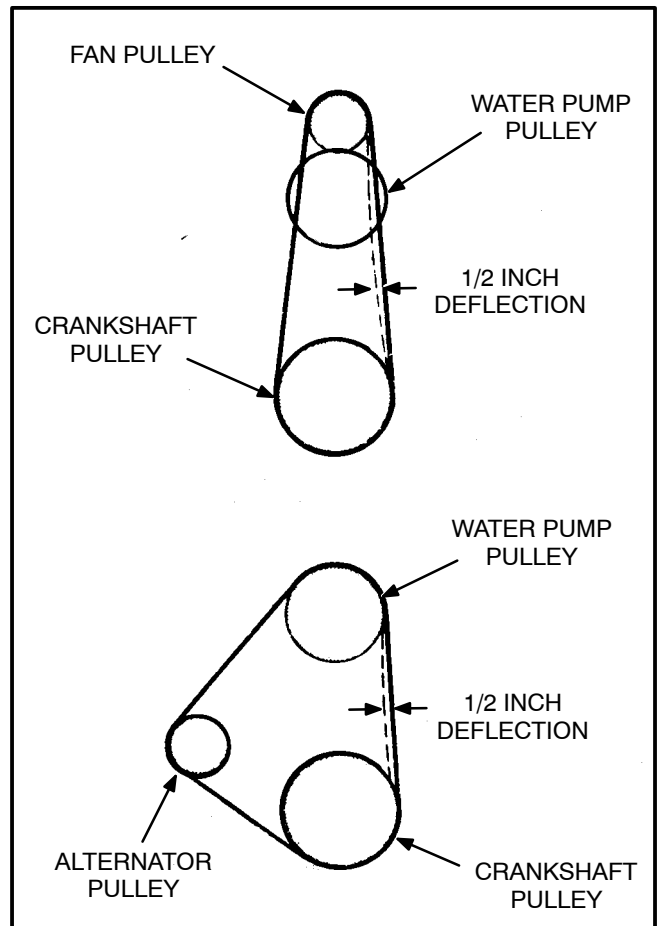

FIGURE 5-7. DRIVE BELT ADJUSTMENT



## IGNITION SYSTEM

The ignition system consists of the distributor, ignition coil, high tension wires, spark plugs and electronic control module. Maintenance consists of periodic inspections to detect possible problems and replacement of worn or deteriorated parts. The ignition system must be completely functional or the set may run poorly or be unable to carry full load. Perform the following inspections at recommended intervals.

### Distributor Cap

Remove the distributor cap and inspect the inside for cracks, burn marks, deterioration of the carbon button or eroded terminals. Replace the cap if any of these conditions are noted.

### Rotor

While the distributor cap is removed, inspect the rotor for cracks, excessive burning of the tip, deterioration of the center spring terminal. Replace the rotor if any of these conditions are noted.

### Spark Plugs

Remove the spark plugs and inspect for damaged or cracked insulators, worn electrodes, damaged gaskets or excessive carbon deposits. Replace the spark plug if any of these conditions are noted. Clean those plugs that can be reused and regap (Figure 5-8) to the amount specified in the Specifi-

cations section. Clean all dirt and grit away from the spark plug seats before installing plugs.

If the spark plugs show any of the following conditions, the engine may require additional service. Contact your authorized service distributor for help.

- Carbon Fouled - Overly Rich Mixture
- Oil Fouled - High oil consumption
- Burned - Excessive engine temperature

### High Tension Wires

Check the spark plug wires and coil wire for good contact at the coil, distributor cap and spark plugs. Terminal connections should be tight and fully seated. All spark plug covers and cable end boots should be in good condition and fit tightly. There should be no breaks or cracks in the insulation. Replace the wire if any of these conditions are noted.

**⚠ CAUTION** *High tension wires can be damaged if removed incorrectly from terminals. Grasp wire by spark plug boot to prevent damage to conductor.*

### Ignition Coil

Clean the top of the ignition coil and check for cracks, carbon tracks or corrosion in the high tension terminal hole. Replace the coil if any of these conditions are noted.

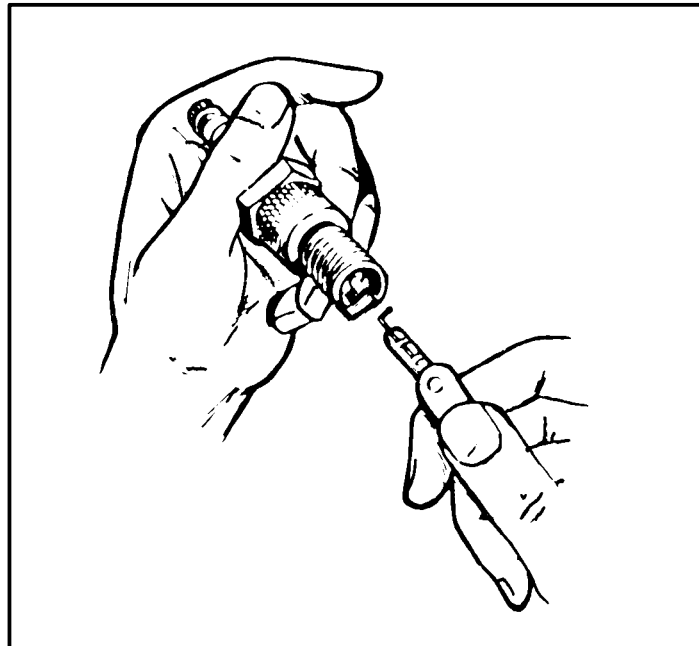

FIGURE 5-8. GAPPING SPARK PLUGS

## BATTERY

Check the battery every month or at least every 100 operating hours. Add distilled water as necessary and check specific gravity. Recharge the battery if the specific gravity is less than 1.260. Clean and tighten the battery terminals and cable connectors and coat with Vaseline to retard corrosion.

**⚠WARNING** *Battery gases are explosive and can cause severe personal injury if ignited. Do not smoke near batteries. Wear protective goggles, rubber gloves and an apron.*

## OUT-OF-SERVICE PROTECTION

When the set will be stored or removed from operation for an extended period of time, take the following precautions to prevent rust accumulation, corrosion of bearing surfaces within the engine and gum formation in the fuel system.

### Preparing Set for Storage

1. Exercise the set as described in Operation section until the engine is up to operating temperature.
2. Shut down the engine.
3. Drain the engine oil while still warm and refill with new oil recommended for set. Attach a tag indicating type of oil used.
4. Remove the spark plugs and pour two ounces of rust preventative oil into each spark plug opening. Crank the set for five seconds to distribute the oil on the cylinder walls and then replace the spark plugs.
5. Drain the cooling system including the engine block.
6. Remove the air cleaner and seal off the carburetor air inlet opening and PVC hose.
7. Plug the exhaust outlets to prevent entrance of moisture, bugs, dirt, etc.
8. Disconnect battery and store in a cool, dry place. Connect battery to charger every 30 days to maintain it at full charge.
9. Clean and wipe entire unit. Coat parts susceptible to rust with a light coat of oil. Cover entire set loosely after engine has cooled down.

### Returning Set to Service

1. Remove protective cover.
2. Remove exhaust plugs, seal from carburetor and PVC hose and replace air cleaner.
3. Check oil dipstick to make sure crankcase is full.
4. Refill cooling system.
5. Reconnect battery and check specific gravity.
6. Remove all loads before starting set.
7. Start set and apply load of at least 50% of nameplate rating.
8. Check all gauges for normal readings. Set is now ready for service.

# 6. Adjustments

---

## OUTPUT VOLTAGE ADJUSTMENT

Output voltage can be adjusted plus or minus five percent of nominal voltage by the Voltage Adjust rheostat (optional) on the control panel (Figure 3-3). Call your distributor if the required voltage cannot be obtained by this adjustment.

## FUEL SYSTEM ADJUSTMENTS

The engine is equipped with a carburetor to run on unleaded gasoline and/or a gas mixer to run on natural gas or propane or both.

**⚠ WARNING** *Fuel is highly flammable and may cause severe personal injury and property damage. Do not allow cigarettes, flame, pilot lights, arching switches or equipment in area or areas sharing ventilation.*

### Gasoline Fuel System

A gasoline carburetor (Figure 6-1) is provided for gasoline fuel systems. The main and idle mixture, and choke are adjustable on the gasoline carburetor. The main adjusting needle, at the bottom of the carburetor, affects operation at heavier load conditions. The idle adjusting needle, at the side of the carburetor, affects operation at light and no load conditions.

Under normal circumstances, factory carburetor adjustments should not be disturbed. If adjustments have been changed, an approximate setting of 1-1/2 turn open for idle needle and one turn open for main needle will permit starting. Adjust temporarily for smoothest running. Allow engine to thoroughly warm up before making final adjustment.

**Idle Mixture Adjustment:** If the adjustment has been disturbed or the engine performs poorly under light load, make the following adjustments.

1. Shut off the engine and turn the idle adjustment screw in gently until it bottoms, and then turn it out 1-1/2 turns so that the engine will run.

**⚠ CAUTION** *The adjustment screw and seat are easily damaged. Do not force the adjustment screw.*

2. Start the engine and let the set warm up under a partial load (at least 1/4 rated load) and then disconnect all loads.
3. Turn the idle adjustment screw out (counterclockwise) approximately one half turn and jounce the throttle. If the engine begins to hunt, turn the adjustment screw in slowly until engine speed becomes stable. If one half turn does not cause instability, turn the adjustment screw out one half turn more and repeat the procedure.

**Main Mixture Adjustment:** If the adjustment has been disturbed or the engine performs poorly under heavy load, make the following adjustments.

1. Shut off the engine and turn the main adjustment screw in gently until it bottoms, and then turn it out 1 turn so that the engine will run.
2. Start the engine and let the set warm up under a partial load (at least 1/4 rated load) and then apply a full load.
3. Slowly turn needle out until speed no longer rises. Try various electrical loads. If engine speed fluctuates at any load, turn main adjusting needle out slightly. Do not turn out more than 1/2 turn beyond original full load setting.
4. If stable speed cannot be obtained by adjusting main adjusting needle, a change in governor sensitivity adjustment will probably be necessary.

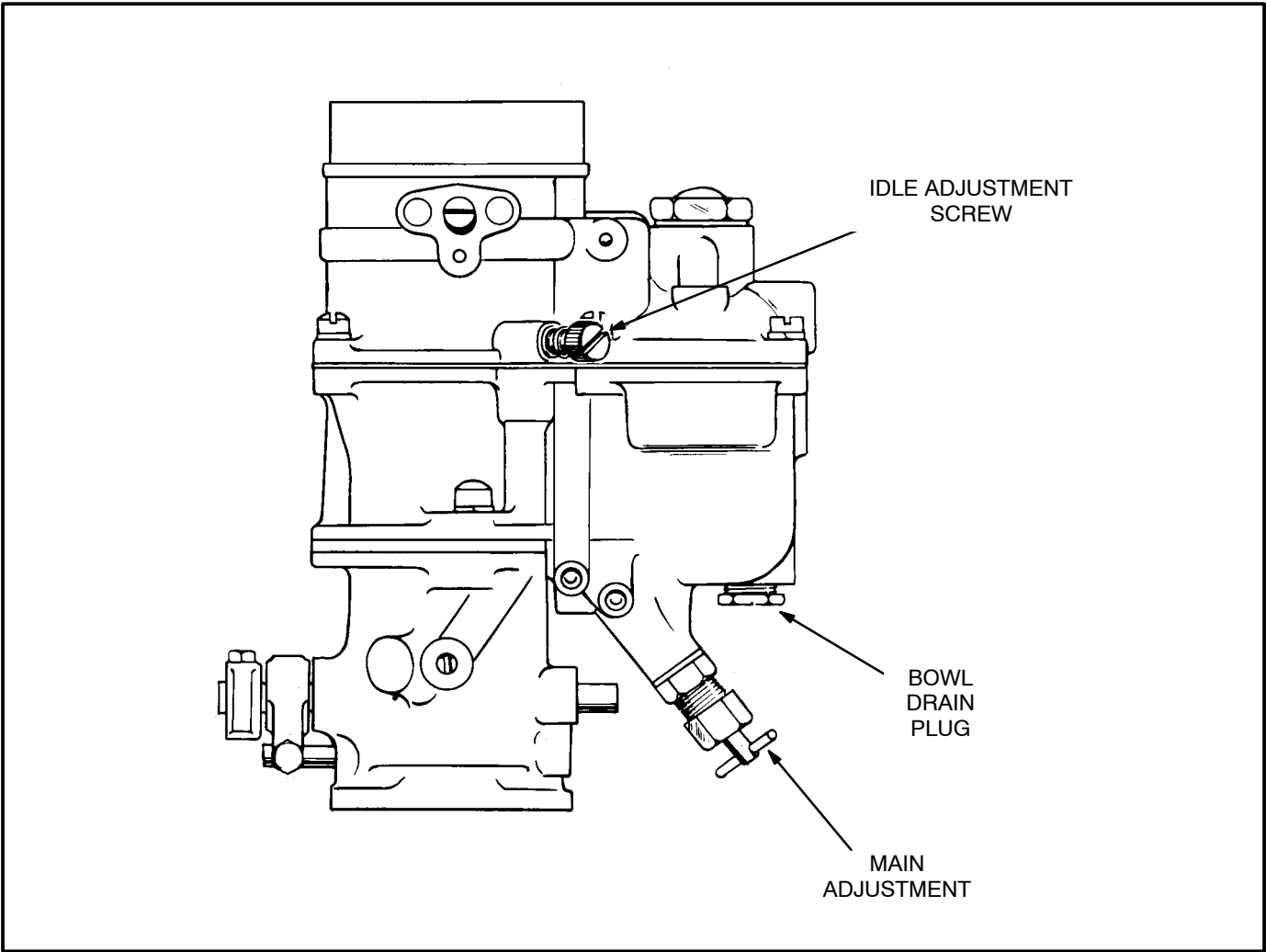
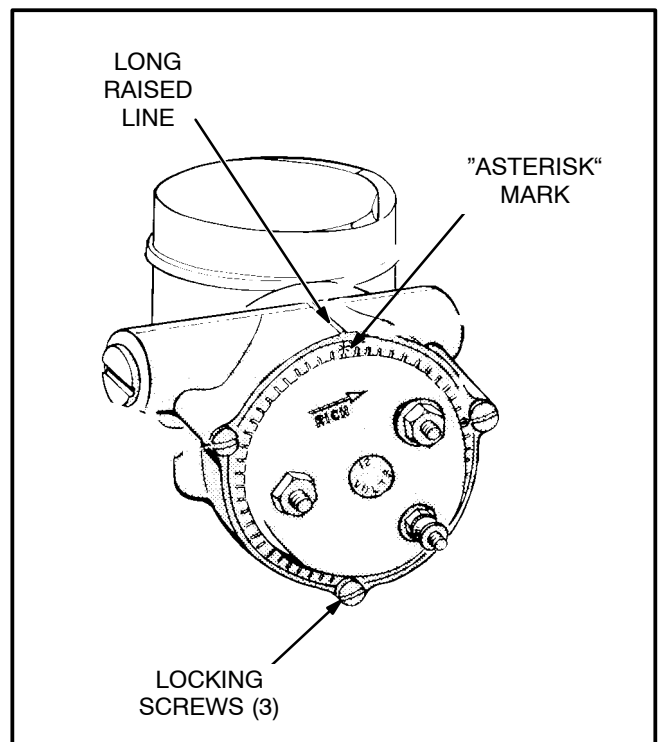

FIGURE 6-1. GASOLINE CARBURETOR

**Choke Adjustment for Gasoline carburetor:** The gasoline carburetor is equipped with an automatic choke for easier cold weather starting. The choke has a bi-metal coil that progressively closes the choke plate as ambient temperature drops, in preparation for the next start. It also has an electric heating element that heats the bi-metal coil to fully open the choke soon after the engine starts.

The choke housing cover can be rotated to adjust the choke. The perimeter of the cover is graduated with evenly spaced lines cast in it. One of the lines has an asterisk (\*). For normal adjustments, the asterisk (\*) should line up with the line cast in the edge of the housing.

1. For better starting in cold weather, loosen the three cover screws (Figure 6-2) and rotate the cover clockwise (richer) so that the asterisk (\*) is one or two lines past the line on the housing and re-tighten the cover screws.
2. For better starting in warm weather, loosen the three cover screws and rotate the cover counterclockwise (leaner) so that the asterisk (\*) is one or two lines past the line on the housing and re-tighten the cover screws.



**FIGURE 6-2. ELECTRIC CHOKE**

## Gaseous and Combination Fuel Systems

An engine equipped for gasoline and natural gas or propane has a regular gasoline carburetor with a gas mixer mounted on the horn of the carburetor. The carburetor throttle serves both fuels. Each fuel has a separate shutoff solenoid valve. The position of the fuel selector switch (mounted at the base of the carburetor) determines which solenoid valve will open for operation.

An engine equipped for natural gas and propane has a gas mixer that serves both fuels. Each fuel has a separate shutoff solenoid valve and either a manual fuel selector switch or a fuel pressure switch for automatic fuel changeover. (While the engine is running, the gas pressure switch causes the

natural gas solenoid valve to close and the propane solenoid valve to open when natural gas pressure is lost, without stopping the engine. When natural gas pressure is restored, the natural gas solenoid valve opens and the propane solenoid valve closes.)

**Choke Adjustment for Combination Carburetor:** If the engine is equipped with a combination carburetor, see that the gasoline shut-off valve is closed. The electric choke (Figure 6-2) must be adjusted so the adjustable cover is turned 10 to 12 notches counterclockwise from the asterisk (\*) mark. When properly adjusted, the electric choke will be completely open even at very low temperatures.

Gas fuel main adjustment should be made at full load only.

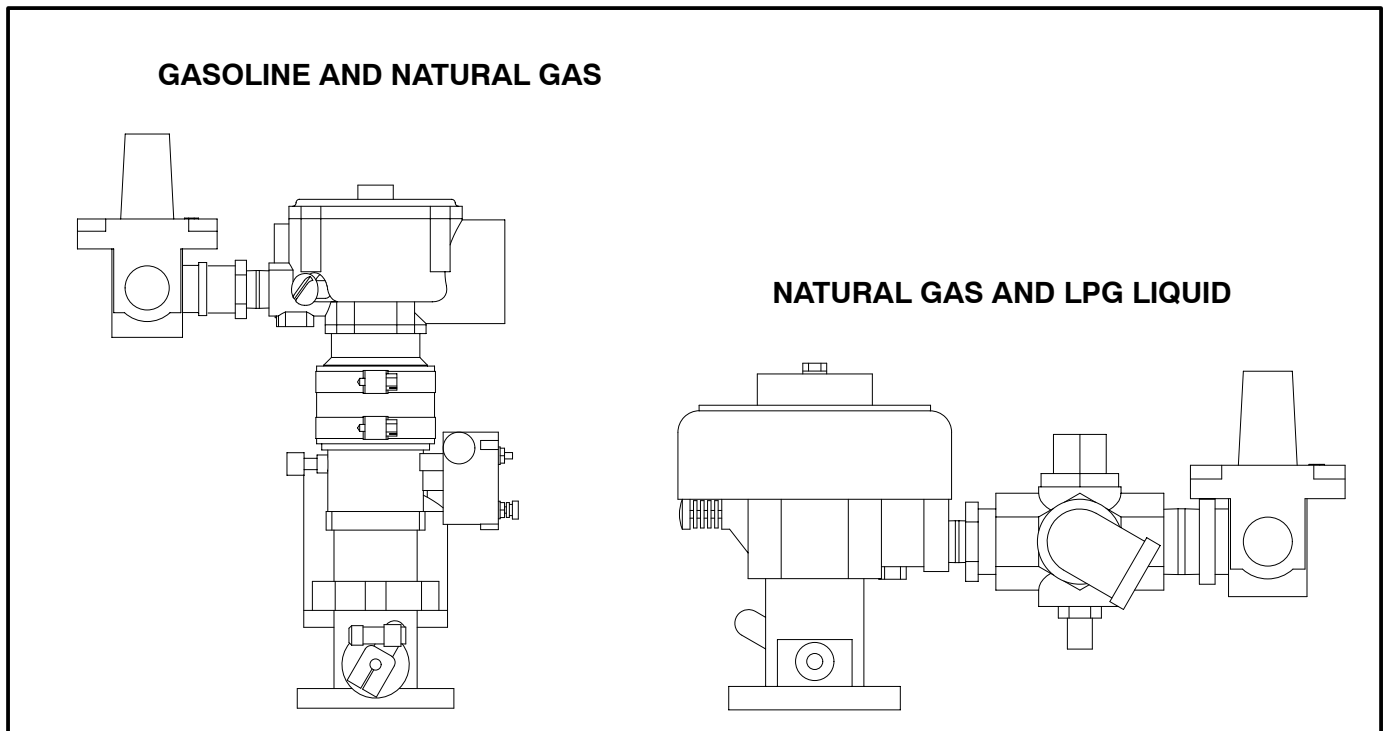
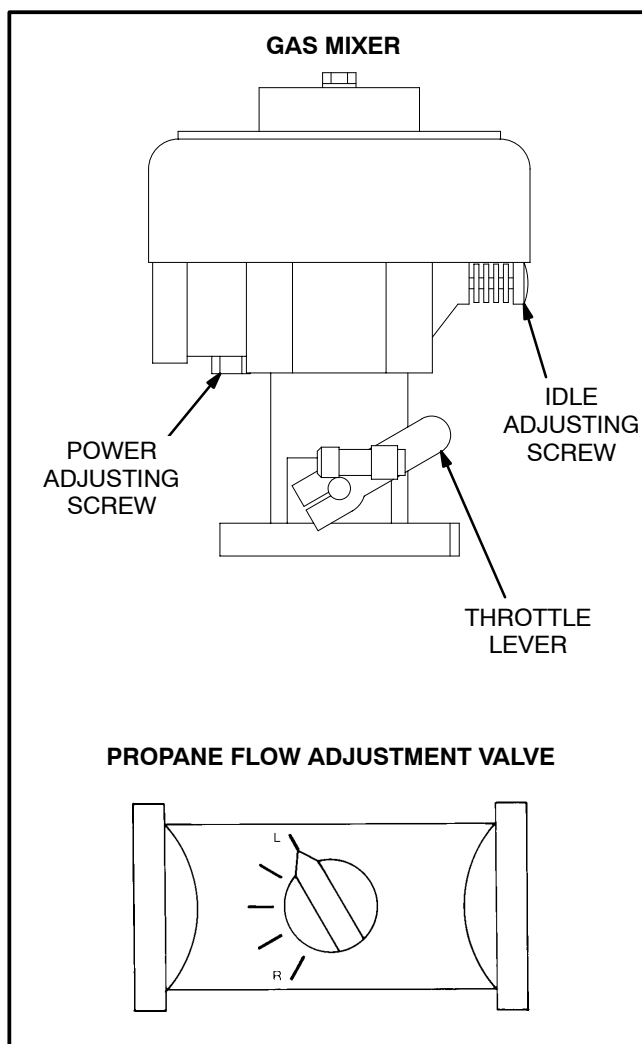

FIGURE 6-3. COMBINATION FUEL SYSTEMS

**Gaseous Fuel Adjustments:** Gas mixers have power and idle adjustment screws. Engines equipped for natural gas and propane also have a propane flow adjustment valve. If necessary, make the following adjustments.

1. Start the engine and let the set warm up under a partial load (at least 1/4 rated load). If the engine is equipped for natural gas and propane, start with natural gas.
2. Disconnect all loads, shut down the set, connect a tachometer and disconnect the governor linkage at the carburetor. Start the engine and close the throttle by hand so that the engine does not overspeed. While holding the throttle closed, adjust the throttle idle position screw (the one next to the throttle lever) to obtain an engine speed of 900 RPM. Then turn the idle adjusting screw counterclockwise until engine speed becomes unstable. Turn the screw clockwise just enough to regain stability and reconnect the governor linkage.
3. Next, connect full rated load and turn the power adjusting screw clockwise until the engine begins to lose speed and then slowly back out the screw (counterclockwise) until the engine carries the full load smoothly.
4. If the set is equipped for natural gas and propane, switch to propane by means of the control panel switch (if provided) or by closing the manual shutoff valve in the natural gas supply line.
5. Reconnect full rated load and turn the propane flow adjustment valve clockwise until the engine begins to lose speed and then slowly turn it back counterclockwise until the engine carries full load smoothly.



**FIGURE 6-4. GASEOUS FUEL ADJUSTMENTS**

**Cummins Power Generation**  
1400 73rd Avenue N.E.  
Minneapolis, MN 55432  
1-800-888-6626  
763-574-5000 International Use  
Fax: 763-528-7229

Cummins is a registered trademark of Cummins Inc.



Redistribution or publication of this document by any means, is strictly prohibited.